



SMART INDUSTRY SOLUTIONS



● LANE RADAR

LANE RADAR

SMART LANE DETECTION

The system allows the driver to be assisted during the maneuver thanks to the detection of obstacles in the environment.

Obstacles are reported using visual devices like semaphores and HMI display, but otherwise the driver can be alerted thanks to the progressive slowdown of the vehicle until it stops before the collision.

The system is installed directly on the rear of the vehicle and it can detect obstacles thanks to laser sensors.

The product has 11 lasers that gives very high accuracy to the system. It also allows to manually draw different areas of working.





Through the integration with the ETS system, the status of the surrounding area can be seen directly on a single touch display.

Using the configuration tool, it is possible to draw any type of polygon to better calibrate the system based on the working environment.

It is possible to install one or more sensors in the system to get complete coverage of the area at risk.

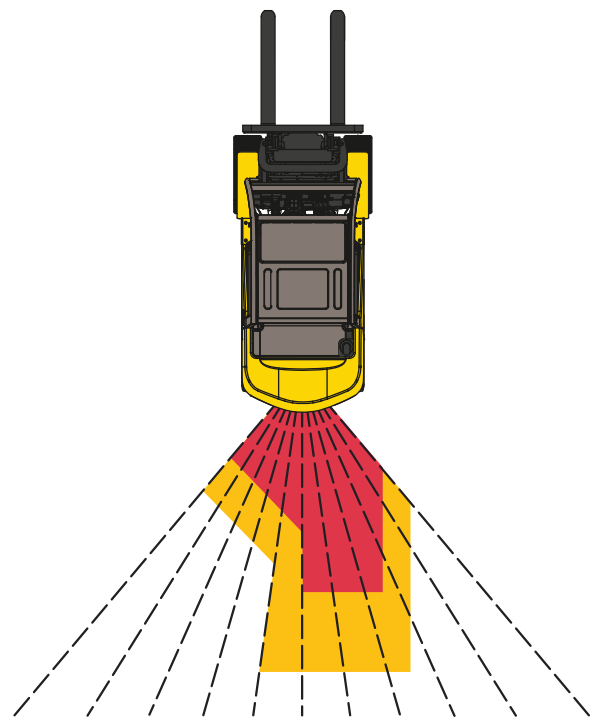
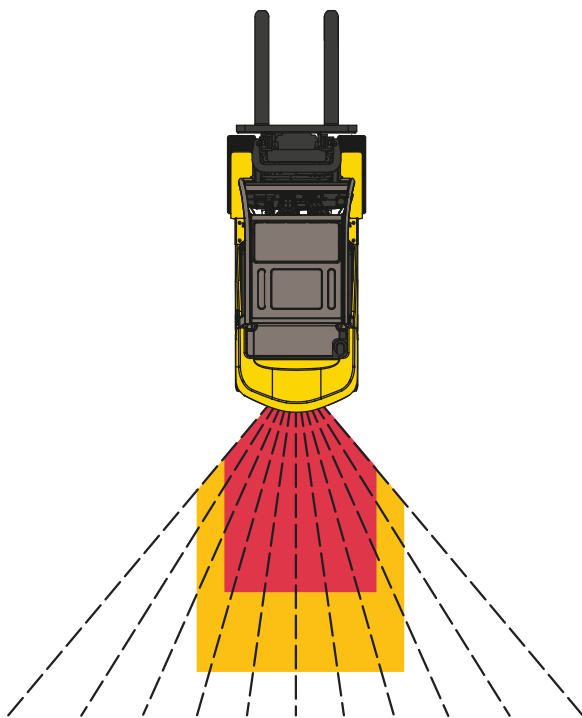

 Via Vizzano 44 Sasso Marconi (BO)

 +39 051 1889 3470  info@kiwitron.it

 www.kiwitron.it